

20

GEREEDSCHAPPEN VOOR AFWERKING *OUTILS DE FINITION*

SCHILDERSMESSEN EN VOEGSPATELS

AFSCHRAAPGEREEDSCHAP

DIVERSE GEREEDSCHAPPEN

GEREEDSCHAP VOOR ISOLATIE

MENGSTANGEN

GEREEDSCHAP VOOR GIPSPLATEN

PLATENLIFT

SCHRAGEN

PLATENKAR

COUTEAUX ET SPATULES

OUTILS DE RACLAGE ET DÉCAPAGE

OUTILS DIVERS

OUTILS POUR ISOLATION

MÉLANGEURS

OUTILS DE PLAQUISTE

LÈVE-PLAQUES

TRÉTEAUX

CHARIOT PORTE-PLAQUES



 Roger
MONDELIN







 **EDMA**
UN OUTIL D'AVANCE

 **PINGUIN**
PROFESSIONNEL TOOLS

 **solid**
HAND TOOLS









DURA-HAMMERGRIP voegspatel met hamerkop - inox
DURA-HAMMERGRIP spatule à jointoyer avec tête marteau - inoxydable

code							min.	€
DS 04280	vrac	5420000003132	100 mm	0,144 kg	144	24	1	13,95
DS 04300	vrac	5420000003071	150 mm	0,160 kg	144	24	1	15,81
+ BIT								
DS 04809	vrac	5420000004849	150 mm	0,178 kg	144	12	1	16,53

DS 04809

+ Bit PH2

DURA-HAMMERGRIP SK2 voegspatel, plamuurmes met hamerkop - inox
DURA-HAMMERGRIP SK2 spatule de peintre avec tête marteau - inoxydable











code							min.	€
DS 62080	vrac	5420000016699	100 mm	0,109 kg	144	12	1	7,00
DS 62090	vrac	5420000016705	125 mm	0,123 kg	144	12	1	8,15
DS 62100	vrac	5420000016712	150 mm	0,130 kg	144	12	1	8,80
DS 62110	vrac	5420000036710	200 mm	0,164 kg	144	12	1	15,43











UIT EÉN DEEL • EN UNE PIÈCE







Voegspatel uit één deel met ergonomische handgreep - inox
Spatule à jointoyer en une pièce avec poignée ergonomique - inoxydable

code							min.	€
NL 3230080		4250226522336	75 mm	0,160 kg	-	12	1	15,00
NL 3230100		4250226522343	100 mm	0,170 kg	-	6	1	15,82
NL 3230130		4250226522350	127 mm	0,190 kg	-	6	1	16,66
NL 3230150		4250226522367	150 mm	0,200 kg	-	6	1	17,25

NYLON-HAMMERGRIP voegspatel - carbon staal
NYLON-HAMMERGRIP spatule à jointoyer - acier carbon

code							min.	€
DS 03100	vrac	5420000003385	150 mm	0,118 kg	192	12	1	13,74





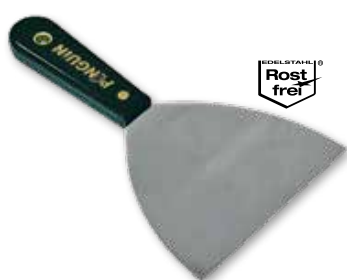

WOOD-HAMMERGRIP voegspatel - inox
WOOD-HAMMERGRIP spatule à jointoyer - inoxydable

code							min.	€
DS 04600	vrac	5420000017030	150 mm	0,130 kg	192	12	1	16,03





NYLON-GRIP voegspatel - inox
NYLON-GRIP spatule à jointoyer - inoxydable

code							min.	€
DS 02080	vrac	5420000003514	100 mm	0,077 kg	192	24	1	7,81
DS 02090	vrac	5420000000872	125 mm	0,082 kg	192	24	1	9,10
DS 02100	vrac	5420000000889	150 mm	0,099 kg	192	24	1	10,42



DURA-GRIP schildersspatel, plamuurmes - inox
DURA-GRIP spatule de peintre - inoxydable

code							min.	€
DS 02220	vrac	542000003408	32 mm	0,064 kg	288	12	1	4,91
DS 02240	vrac	542000003415	50 mm	0,068 kg	288	12	1	5,34
DS 02260	vrac	542000003422	75 mm	0,075 kg	288	12	1	6,83
DS 02280	vrac	542000003439	100 mm	0,090 kg	192	12	1	7,94
DS 02290	vrac	542000003446	125 mm	0,100 kg	192	12	1	9,18
DS 02300	vrac	542000003392	150 mm	0,120 kg	192	12	1	11,21



DURA-GRIP multifunctioneel mes - inox
DURA-GRIP couteau multifonction - inoxydable

code							min.	€
DS 02340	vrac	542000003460	63 mm	0,098 kg	144	12	1	6,83

DURA-HAMMERGRIP afsteekmes met stijf blad, met hamerkop - inox
DURA-HAMMERGRIP riflard à lame rigide, avec tête marteau - inoxydable

code							min.	€
DS 62041	vrac	5420000011205	50 mm	0,104 kg	144	12	1	6,24
DS 62061	vrac	5420000011212	75 mm	0,124 kg	144	12	1	7,49

DURA-HAMMERGRIP multifunctioneel mes met hamerkop - inox
DURA-HAMMERGRIP couteau multifonction avec tête marteau - inoxydable

code							min.	€
DS 61160	vrac	5420000011199	75 mm	0,133 kg	144	12	1	11,31



Beitelmes met hamerkop
Ciseau avec tête à frappe

code								min.	€
TJ SCRC50		4975364017970	50 mm	1,8 mm	0,188 kg	-	12	1	23,51
Visstaart vorm • Forme trapèze									
TJ SCR95		4975364018007	95 mm	1,8 mm	0,204 kg	-	12	1	23,51
Multivorm • Multiforme									
TJ SCRM75		4975364018021	75 mm	1,8 mm	0,184 kg	-	12	1	23,51

Multifunctioneel mes • Couteau multifonction

code							min.	€
TJ DKTN80		4975364164018	mes / lame - 70 mm	0,166 gr	-	10	1	33,77



20 GEREEDSCHAP VOOR AFWERKING OUTILS DE FINITIONS

SCHILDERSMESSEN EN VOEGSPATELS
COUTEAUX ET SPATULES



TOPFLEX flexibel schildersmes - inox TOPFLEX couteau de peintre à lame flexible - inoxydable

code							min.	€
DS 05210	vrac	5420000011151	25 mm	0,075 kg	144	24	1	10,26
DS 05230	vrac	5420000011168	38 mm	0,082 kg	144	24	1	10,45
DS 05240	vrac	5420000011175	50 mm	0,086 kg	144	24	1	11,36
DS 05250	vrac	5420000011182	63 mm	0,089 kg	144	24	1	11,75
DS 05260	vrac	5420000011250	75 mm	0,093 kg	144	24	1	12,06
DS 05280	vrac	5420000013919	100 mm	0,099 kg	144	24	1	13,68

Gesmeed uit 1 deel • forgé monobloc



UNI-GRIP schildersmes - inox UNI-GRIP couteau de peintre - inoxydable

code							min.	€
DS 08020	vrac	5420000003156	32 mm	0,052 kg	192	24	1	3,40
DS 08030	vrac	5420000003163	40 mm	0,057 kg	192	24	1	3,98
DS 08040	vrac	5420000003170	50 mm	0,060 kg	192	24	1	4,29
DS 08050	vrac	5420000003187	60 mm	0,064 kg	192	24	1	4,73
DS 08060	vrac	5420000003194	80 mm	0,071 kg	192	24	1	5,66
DS 08080	vrac	5420000003200	100 mm	0,080 kg	192	24	1	6,89
DS 08090	vrac	5420000003217	125 mm	0,084 kg	192	24	1	8,07

Plamuurmes houten greep - staal verchromd Couteau de peintre, manche bois - acier chromé

code							min.	€
MB 102020	vrac	5420000012493	20 mm	0,042 kg	-	12	1	1,74
MB 102030	vrac	5420000012509	30 mm	0,048 kg	-	12	1	2,04
MB 102040	vrac	5420000012516	40 mm	0,050 kg	-	12	1	2,13
MB 102050	vrac	5420000012523	50 mm	0,052 kg	-	12	1	2,25
MB 102060	vrac	5420000012530	60 mm	0,054 kg	-	12	1	2,37
MB 102080	vrac	5420000012547	80 mm	0,058 kg	-	12	1	2,80
MB 102100	vrac	5420000012554	100 mm	0,072 kg	-	12	1	3,29
MB 102120	vrac	5420000012561	120 mm	0,090 kg	-	12	1	3,88



Uitkapmes voor mastiek, PP greep - staal Couteau à démastiquer, manche PP - acier

code							min.	€
MB 101870	vrac	5420000012592	90 x 30 mm	0,067 kg	-	12	1	5,88



Mastiekmes laurierblad, houten greep - staal Couteau à mastiquer feuille de laurier, manche bois - acier

code							min.	€
MB 101930	vrac	5420000012585	110 x 35 mm	0,055 kg	-	12	1	2,92

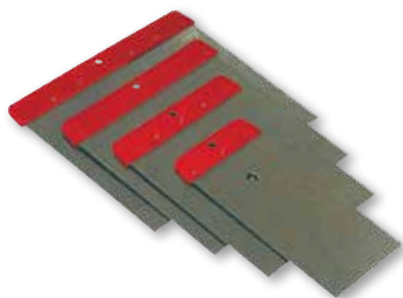

Japane spatelset, 4-delig • Jeu de 4 couteaux Japonais

code							min.	€
Staal • Acier								
PL 606404		5420000000063	50, 80, 100, 120 mm	0,100 kg	-	1	1	1,88
Inox • Inoxydable								
CP 606604		4022307158242	50, 80, 100, 120 mm	0,104 kg	-	100	1	5,50

Schildersspatel soft greep - inox
Couteau à enduire, manche soft - inoxydable

code							min.	€
MB 26001	vrac	5420000023260	100 mm	0,094 kg	-	5	1	6,18
MB 26002	vrac	5420000023277	120 mm	0,104 kg	-	5	1	6,49
MB 26003	vrac	5420000023284	140 mm	0,117 kg	-	5	1	6,94
MB 26004	vrac	5420000023291	160 mm	0,130 kg	-	5	1	7,16
MB 26005	vrac	5420000023307	180 mm	0,152 kg	-	5	1	7,56
MB 26006	vrac	5420000023314	200 mm	0,164 kg	-	5	1	8,04

Schildersspatel houten greep - staal
Couteau à enduire, manche bois - acier

code							min.	€
MB 160120	vrac	5420000012424	120 mm	0,126 kg	-	5	1	4,03
MB 160140	vrac	5420000012431	140 mm	0,137 kg	-	5	1	4,37
MB 160160	vrac	5420000012448	160 mm	0,144 kg	-	5	1	4,80
MB 160180	vrac	5420000012455	180 mm	0,180 kg	-	5	1	5,09
MB 160200	vrac	5420000012462	200 mm	0,195 kg	-	5	1	6,18
MB 160240	vrac	5420000012479	240 mm	0,202 kg	-	5	1	6,67

ERGO-SOFT breedspatel - inox
ERGO-SOFT couteau à enduire - inoxydable

code							min.	€
DS 36061	vrac	5420000003538	200 mm	0,246 kg	72	12	1	12,14
DS 36062	vrac	5420000003545	250 mm	0,289 kg	72	12	1	13,68
DS 36063	vrac	5420000003552	300 mm	0,318 kg	72	12	1	15,36
DS 36064	vrac	5420000018396	350 mm	0,348 kg	72	12	1	18,16

Rubberspatel voor het afdichten van inwendige hoeken van 60° tot 170°, hoekige, ronde en moeilijk toegankelijke gedeelten
Couteau à enduire caoutchouc pour enduire les angles intérieurs de 60° à 170°, les parties angulaires, arrondies et difficiles d'accès.

code							min.	€
ED 164055		3476060016409	60° → 170°	0,390 kg	-	12	1	18,78
Steel • Manche								
MS 8090	vrac	5420000010864	L Ø a Ø b	0,505 kg	-	25	25	4,97



DIKTE • ÉPAISSEUR
0,5 mmDIKTE • ÉPAISSEUR
0,7 mm
Spackmes met DURA-SOFT greep - inox
Couteau à enduire avec manche DURA-SOFT - inoxydable

code									min.	€
Flexibel • Flexible										
DS 008020	vrac	5420000012370	200 mm	0,5 mm	0,240 kg	600	60	10	1	9,80
DS 008028	vrac	5420000001190	300 mm	0,5 mm	0,315 kg	720	60	10	1	11,44
DS 008038	vrac	5420000001206	400 mm	0,5 mm	0,377 kg	660	60	10	1	13,71
DS 008048	vrac	5420000001213	500 mm	0,5 mm	0,447 kg	480	60	10	1	15,85
DS 008057	vrac	5420000001220	600 mm	0,5 mm	0,507 kg	360	60	10	1	18,10
Stijf blad • Lame rigide										
DS 008938	vrac	5420000017054	400 mm	0,7 mm	0,414 kg	600	60	10	1	14,87
DS 008948	vrac	5420000003095	500 mm	0,7 mm	0,492 kg	480	60	10	1	16,81
DS 008960	vrac	5420000017061	600 mm	0,7 mm	0,554 kg	360	60	10	1	18,70

ALU basis • Support ALU

DIKTE • ÉPAISSEUR
0,7 mm
Spackmes met DURA-SOFT greep, met tanding 6x6 mm - inox
Couteau à enduire avec manche DURA-SOFT, avec denture 6x6 mm - inoxydable

code									min.	€
DS 004906	vrac	5420000042964	500 mm	0,7 mm	0,444 kg	-	10	1	16,97	

Spackmes met houten greep - inox blad
Couteau à enduire, manche bois - lame inoxydable

code								min.	€
DS 004540	vrac	5420000042933	400 mm	0,7 mm	0,274 kg	-	10	1	9,02
DS 004650	vrac	5420000042940	500 mm	0,7 mm	0,398 kg	-	10	1	10,42
DS 004860	vrac	5420000042957	600 mm	0,7 mm	0,471 kg	-	10	1	12,73

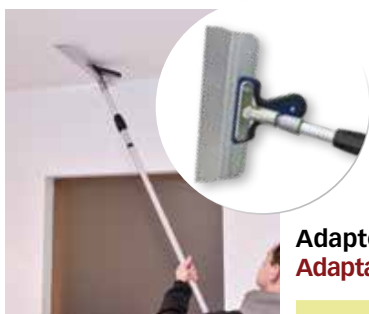
Adapter en telescoopstang voor spackmes "DURA-SOFT", SK-2
Adaptateur et perche télescopique pour couteau à enduire "DURA-SOFT", SK-2

code							min.	€
Adapter • Adaptateur								
DS 009275	vrac	5420000035690	-	0,112 kg	-	12	1	5,25
Telescoopstang • Perche télescopique								
DS 009200	vrac	5420000035683	120 → 210 cm	0,608 kg	-	2	1	17,65

Spackmes met ergonomische handgreep in kurk - inox blad
Couteau à enduire avec poignée ergonomique en liège - lame inoxydable

code								min.	€
NL 405630		4250226520615	300 mm	0,4 mm	0,280 kg	-	6	1	15,71
NL 405640		4250226520622	400 mm	0,4 mm	0,340 kg	-	6	1	16,66
NL 405650		4250226520639	500 mm	0,4 mm	0,400 kg	-	6	1	18,32
NL 405660		4250226520646	600 mm	0,4 mm	0,470 kg	-	6	1	19,99
NL 405680		4250226520653	800 mm	0,4 mm	0,590 kg	-	6	1	27,71



MB 575060



MB 575100

DIKTE • ÉPAISSEUR
0,30
mm

"FLEXO-LITE" spackmes met vervangbaar lemmet
Couteau à enduire "FLEXO-LITE" avec lame interchangeable



MB 575025



MB 580041

code								min.	€
MB 575025		5420000062832	250 mm	0,30 mm	0,450 kg	-	1	1	32,55
MB 575040		5420000062849	400 mm	0,30 mm	0,800 kg	-	1	1	45,26
MB 575060		5420000062856	600 mm	0,30 mm	1,200 kg	-	1	1	63,70
MB 575080		5420000062863	800 mm	0,30 mm	1,600 kg	-	1	1	74,20
MB 575100		5420000062870	1000 mm	0,30 mm	1,800 kg	-	1	1	91,10
Vervangbladen • Lames de rechange									
MB 580026		5420000062887	250 mm	0,30 mm	0,054 kg	-	1	1	14,33
MB 580041		5420000062894	400 mm	0,30 mm	0,080 kg	-	1	1	19,59
MB 580061		5420000062900	600 mm	0,30 mm	0,122 kg	-	1	1	25,64
MB 580081		5420000062917	800 mm	0,30 mm	0,162 kg	-	1	1	35,02
MB 580101		5420000062924	1000 mm	0,30 mm	0,206 kg	-	1	1	42,56



Telescopische steel + klem voor "FLEXO-LITE" spackmes
Manche télescopique + pince pour couteau à enduire "FLEXO-LITE"

code							min.	€
MB 580550	vrac	5420000062931	135 → 235 cm	0,852 kg	-	1	1	64,50



OOK VOOR AIRLESS
AUSSI POUR PROJECTAGE



DIKTE • ÉPAISSEUR
0,3
mm

"FINISH" spackmes - Bi-flex - inox
Couteau à enduire "FINISH" - Bi-flex - inoxydable

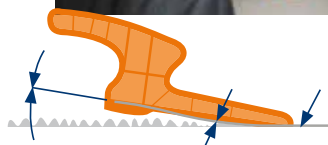

Maakt het mogelijk om grote oppervlakken op zeer hoge snelheid perfect glad te maken, zonder coatingverlies en vrijwel zonder schuren.

Permet un lissage sans bavures sur de grandes surfaces, à de très grandes cadences, sans perte d'enduit et pratiquement sans ponçage.

code								min.	€
MB 350035		5420000023369	350 mm	0,3 mm	0,380 kg	-	50	1	30,80
MB 350045		5420000023222	450 mm	0,3 mm	0,471 kg	-	50	1	39,70
MB 350060		5420000023239	600 mm	0,3 mm	0,655 kg	-	50	1	51,10
MB 350080		5420000023246	800 mm	0,3 mm	0,894 kg	-	50	1	67,70

Alusteel voor "FINISH" spackmes
Perche en alu pour couteau à enduire "FINISH"

code							min.	€
MB 351000	vrac	5420000023253	100 → 200 cm	0,725 kg	-	1	1	66,50



 DIKTE • ÉPAISSEUR
1,2 mm
Gipsmes met houten greep, stijf blad - staal
Couteau de plâtrier, monture bois, lame rigide - acier

code								min.	€
CP 314130	vrac	4022307118123	300 mm	1,2 mm	0,233 kg	-	1	1	14,27
CP 314140	vrac	4022307118130	400 mm	1,2 mm	0,320 kg	-	1	1	19,01
CP 314150	vrac	4022307118154	500 mm	1,2 mm	0,418 kg	-	1	1	21,86

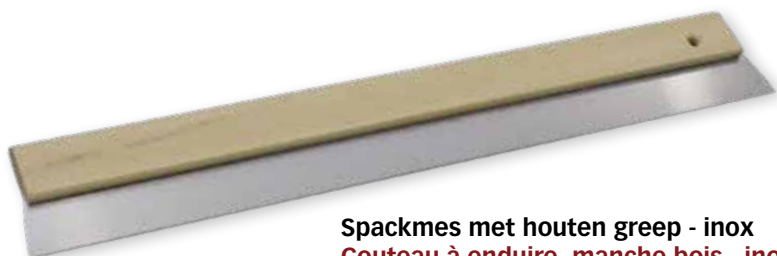
 DIKTE • ÉPAISSEUR
0,7 mm
Spackmes met houten greep - inox
Couteau à enduire, manche bois - inoxydable

code								min.	€
DS 005800	vrac	5420000024489	800 mm	0,7 mm	0,706 kg	-	1	1	28,46

 DIKTE • ÉPAISSEUR
0,5 mm

CP 292210











Spackmes ALU profiel XXL met vervangbaar blad
Couteau à enduire ALU profile XXL avec lame interchangeable

code								min.	€
CP 292210	vrac	4022307177540	1000 mm	0,5 mm	2,100 kg	-	1	1	76,80
Vervangblad • lame de rechange								Per 5 st • Par 5 pcs	
CP 292305		4022307178158	1000 mm	0,5 mm	0,450 kg	-	1	1	56,80







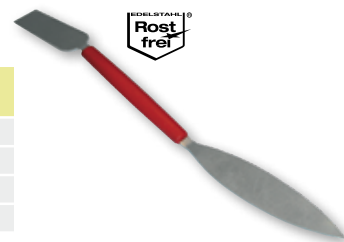

CP 292305

Plaastrvoegmes, vlak en gepunt
Fer de plâtrier, plat et pointu

code								min.	€
CP 159010		4022307103846	10 mm	0,5 mm	0,032 kg	-	1	1	5,43
CP 159014		4022307103860	14 mm	0,5 mm	0,036 kg	-	1	1	5,43
CP 159020		4022307103891	20 mm	0,5 mm	0,043 kg	-	1	1	5,43
CP 159030		4022307103938	30 mm	0,5 mm	0,058 kg	-	1	1	6,87

Verfscraper, houten greep • Grattoir à peinture, manche bois











code							min.	€
Met driehoekig lemmet • Avec lame triangulaire								
DS 06655	vrac	5420000012363	60 mm	0,124 kg	144	12	1	6,24
Met multi-functioneel lemmet • Avec lame multi-forme								
DS 06650	vrac	5420000011144	50 mm	0,132 kg	144	12	1	8,46

Handschraper alu steel met kunststof greep, vervangbaar lemmet
(hardmetaal)
Racloir avec manche en alu et poignée en plastique, lame interchangeable
(carbure de tungstène)

FC 610025

FC 610050

FC 610060

code							min.	€
Met driehoekig lemmet • Avec lame triangulaire								
FC 610025		5420000012127	20 mm	0,178 kg	96	6	1	12,96
Met recht lemmet • Avec lame droite								
FC 610050		5420000012134	50 mm	0,209 kg	-	6	1	17,06
Met recht lemmet + bol • Avec lame droite + boule								
FC 610060		5420000012141	60 mm	0,276 kg	72	6	1	22,01
Vervanglemmets per stuk verpakt • Lames de recharges emballées par pièce								
FC 610026		5420000012158	20 mm	0,017 kg	-	10	1	7,16
FC 610051		5420000012165	50 mm	0,020 kg	-	10	1	7,80
FC 610061		5420000012172	60 mm	0,021 kg	240	10	1	12,33





Afschraper/beitel - Flexibel lemmet
Grattoir/burin - Lame flexible

Tajima

code							min.	€
TJ PHR250F80		4975364058065	280 x 80 mm	0,360 kg	-	6	1	46,00
Flexibel vervanglemmet • Lame de rechange flexible								
TJ PHR-FB80		4975364058089	80 x 0,5 mm	0,050 kg	-	1	1	7,14

DIKTE • ÉPAISSEUR
0,5 mm



Afschraper/beitel met hamerkop - Extra hard lemmet
Grattoir/burin avec tête marteau - Lame extra rigide

Tajima

code							min.	€
TJ PHR250H80		4975364058041	285 x 80 mm	0,435 kg	-	6	1	52,10
TJ PHR500H80		4975364058058	565 x 80 mm	0,610 kg	-	6	1	61,30
Extra hard vervanglemmet • Lame de rechange extra rigide								
TJ PHR-HB80		4975364058072	80 x 1,2 mm	0,085 kg	-	1	1	11,42

DIKTE • ÉPAISSEUR
1,2 mm

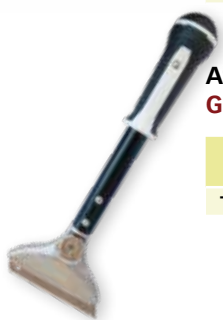

Afschraper Rite-P
Grattoir Rite-P

Tajima

code								min.	€
TJ PSCL300F		4975364058034	305 mm	18 mm	0,430 kg	-	6	1	49,10

inclusief 3 vervangbladen • 3 lames de rechanges incluses

Afschraper in aluminium
Grattoir en aluminium

code								min.	€
TJ SCRL300		4975364016133	300 mm	18 mm	0,380 kg	-	4	1	31,05
TJ SCRL600		4975364016140	600 mm	18 mm	0,558 kg	-	4	1	38,82
TJ SCRH1200		4975364019967	1200 mm	25 mm	1,215 kg	-	4	1	53,00

inclusief 3 vervangbladen • 3 lames de rechanges incluses

Tajima

PINGUIN



Universele afschraper met vervangbaar lemmet
Grattoir universel avec lame interchangeable







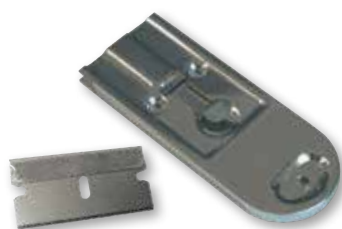

code							min.	€
FC 615100		5420000012011	300 x 100 mm	0,226 kg	120	20	1	8,19
FC 615150		5420000012035	600 x 150 mm	0,470 kg	-	12	1	13,65
Vervanglemmets • Lames de rechanges								
FC 615101		5420000012028	100 mm	0,066 kg	200	25	1	3,57
FC 615151		5420000012042	150 mm	0,162 kg	-	10	1	6,38

Per 10 st • Par 10 pcs







Per 5 st • Par 5 pcs





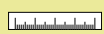



Metalen glasschraper met vervangbaar lemmet
Gratte vitres monture métallique avec lame interchangeable

code							min.	€
DS 38520		5420000012004	100 x 40 mm	0,056 kg	-	24	1	4,55
Vervanglemmets • Lames de rechanges								Per 5 st • Par 5 pcs
DS 38523		5420000014039	20 x 40 mm	0,019 kg	-	50	1	1,32





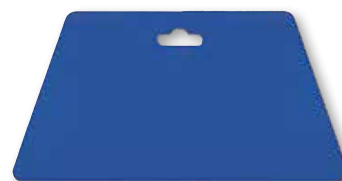

Glasschraper kunststof met vervangbaar lemmet
Gratte vitres plastique avec lame interchangeable

code							min.	€	
PL 525000	vrac	5420000012097	170 x 70 mm	0,026 kg	-	-	12	1	1,17
Vervanglemmets • Lames de rechanges								Per 5 st • Par 5 pcs	
ZE 576060		5420000062962	60 x 0,65 x 19 mm	0,030 kg	3800	200	10	10	1,56







Gladstrijkspatel PE trapeziumvorm
Spatule à maroufler forme trapèze en PE

code							min.	€
PL 521000	vrac	5420000012073	240 x 120 mm	0,064 kg	-	30	1	1,22





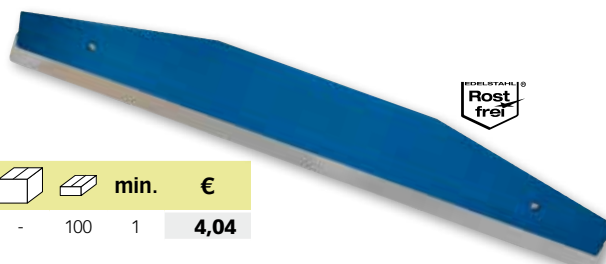

Gladstrijkspatel PE met ingewerkte handgreep
Spatule à maroufler en PE avec poignée incorporée

code							min.	€
PL 521777	vrac	5420000012066	255 x 130 mm	0,076 kg	-	60	1	1,81



Afsnijlat, kunststof basis - inox
Règle de coupe, monture PVC - inoxydable

code							min.	€
PL 520000	vrac	5420000012080	570 mm	0,234 kg	-	100	1	4,04

Behangprikrol voor behang met geharde stalen punten op kunststofbasis met steel
Boucharde à perforer, rouleau en matière plastique avec pointes en acier trempé avec manche

code							min.	€
DS 38450	vrac	5420000012059	475 x 150 mm	0,420 kg	24	6	1	25,39

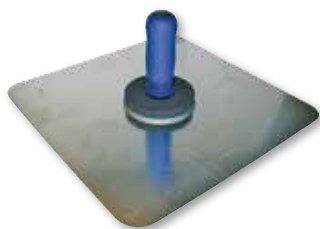

Spachtelbord in ALU • Palette de plâtrier en ALU

code							min.	€
Met ERGO-SOFT handgreep • Avec poignée ERGO-SOFT								
DS 36950	vrac	542000000940	330 x 330 mm	0,775 kg	24	6	1	35,31

Gipsbeker - rubber • Bol à plâtre - caoutchouc

code							min.	€
Klein • Petit								
HH 614001	vrac	4039067119451	127 x 95 mm	0,200 kg	-	300	1	1,98
Groot • Grand								
PP 614100	vrac	5420000012899	160 x 100 mm	0,290 kg	-	40	1	7,37

Pannetje voor stukadoor • Casserole de plâtrier

code							min.	€
PL 637000	vrac	5420000015876	Ø 16 cm	0,334 kg	-	50	1	5,12

Gipserkom - PVC • Cuve à plâtre - PVC

code							min.	€
ED 066955	vrac	3476060006691	300 mm	0,270 kg	-	5	1	8,74

Viltkwast • Brosse avec patins en feutre

code							min.	€
NL 38980023		4250226522183	229 mm	0,450 kg	-	1	1	35,10

Crepimolen • Moulin à crépir

code							min.	€
PM 323331		5420000040212	260 x 160 mm	1,550 kg	-	6	1	32,23
Vervangmolen • Moulin de recharge								
PM 323332		5420000040229	160 x 150 mm	0,558 kg	-	1	1	12,32







Gipskam • Peigne à plâtre

code							min.	€
Met houten handgreep • Avec poignée en bois								
DS 30300	vrac	5420000042971	300 mm	0,256 kg	-	10	1	19,44







Behangerslat - inox • Règle de colleur - inoxydable

code							min.	€
PL 624020	vrac	5420000010529	6 cm x 2 m	0,382 kg	-	20	1	12,79
PL 624030	vrac	5420000010536	6 cm x 3 m	0,574 kg	-	20	1	16,97





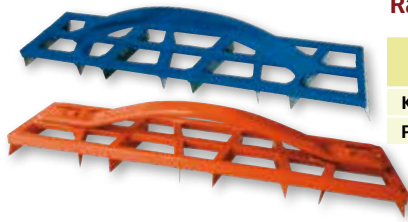

Hoekhouder voor cellenbeton
Equerre d'angle pour béton cellulaire

code							min.	€
TO 19500	vrac	5420000058736	255 x 255 x 265 mm	1,220 kg	-	1	1	22,08







Sleuventrekker voor cellenbeton
Rainureuse manuelle pour béton cellulaire

code							min.	€
TO 19760	vrac	5420000058743	570 mm	0,636 kg	-	1	1	16,42

Gipsschaaf ALU - 8 messen - Geschikt voor gips en gasbeton
Rabot à plâtre ALU - 8 lames - Adapté au plâtre et au béton cellulaire





code							min.	€
KU 353000	vrac	5420000012721	450 x 90 mm	0,684 kg	-	20	1	22,34
PL 353010	vrac	5420000035812	460 x 89 mm	0,967 kg	-	30	1	34,05

Hoekschaaf, houten greep - 6 messen
Rabot à plâtre, manche en bois - 6 lames







code							min.	€
CP 355034	vrac	4022307120300	340 x 40 mm	0,414 kg	-	1	1	27,44



Plafondzaag • Scie de plafond

code							min.	€
CP 354032	vrac	4022307120294	320 mm	0,082 kg	-	1	1	23,46

Gipsrooster rechthoekig
Grille, rabot à plâtre rectangulaire

code							min.	€
KU 25272	vrac	5420000010895	290 x 140 mm	0,784 kg	-	6	1	14,11

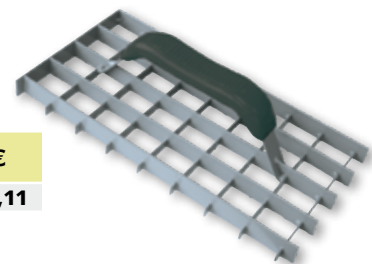



Kunststofspaan met rasp voor Styrofoam
Plâtoir plastique avec rape métallique pour Styrofoam

code							min.	€
Met vervangbaar blad • Avec lame remplaçable								
PL 108127	vrac	5420000034228	275 x 125 mm	0,365 kg	-	15	1	7,01
Met vast blad • Avec lame fixe								
PL 108380	vrac	5420000062542	380 x 160 mm	0,750 kg	-	12	1	11,44

PL 108127

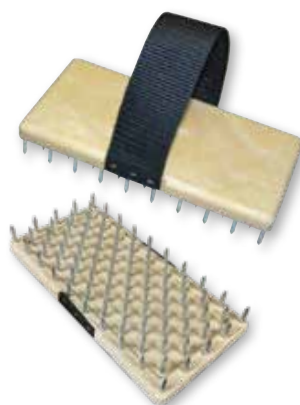

Krabblok kunststof, met riem
Taloche à pointes, poignée sangle

code							min.	€
PL 308018	vrac	5420000000995	180 x 90 mm	0,234 kg	-	10	1	8,84

Krabbord, doorgezette plaat • Taloche gratton, tôle emboutie

code				#					min.	€
Houten handgreep, lange punten • Poignée en bois, pointes longues										
CP 379200	vrac	4022307161860	255 x 155 mm	240	8,5 mm	0,488 kg	-	1	1	11,00
RM 321200	vrac	3479133212005	240 x 140 mm	240	15 mm	0,445 kg	-	6	1	13,42
RM 321210	vrac	3479133212104	250 x 150 mm	480	8 mm	0,380 kg	-	6	1	8,60

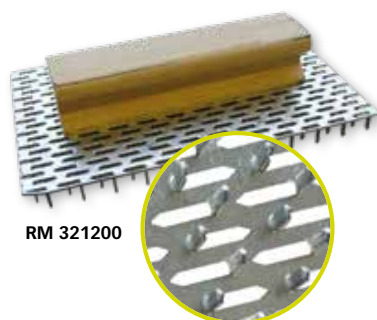

RM 321200

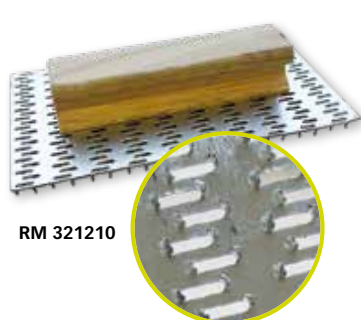

RM 321210



CP 379200

20 GEREEDSCHAP VOOR AFWERKING OUTILS DE FINITIONS

GEREEDSCHAP VOOR ISOLATIE
OUTILS POUR ISOLATION



Tafelzaag voor minerale wol Table de découpe pour laine de roche



code							min.	€
ED 366955	koffer/coffre	3476060036698	H max. 1200 mm D/P max. 260 mm	27,750 kg	-	1	1	981,00

TECHNISCHE GEGEVENS CARACTÉRISTIQUES TECHNIQUES	
Referentie Référence	ED 366955
Snijlengte Longueur de coupe	max. 1200 mm
Snijdiepte Profondeur de coupe	max. 260 mm
Hoeksneede Coupe à angle	0° → 50°
Schuine snede Coupe biseautée	0° → 45°



- Inclusief toebehoren :
- Transportkoffer met wielen
 - 300 mm mes voor isolatiemateriaal
- Accessoires inclus :
- Coffre de transport avec roulettes
 - Couteau de 300 mm pour matériau isolant



Tafelzaag met verwarmde snijdraad voor polystyreen Table de découpe avec fil chaud pour polystyrène



code							min.	€
ED 266555	koffer/coffre	3476060026651	H max. 1320 mm D/P max. 330 mm	19,000 kg	-	1	1	1134,00
ED 367155	koffer/coffre	3476063671551	H max. 1400 mm D/P max. 320 mm	29,300 kg	-	1	1	1320,00

- Inclusief toebehoren :
- Transportkoffer
 - 2 rollen snijdraad
- Accessoires inclus :
- Coffre de transport
 - 2 bobines de fil de coupe



TECHNISCHE GEGEVENS CARACTÉRISTIQUES TECHNIQUES		
ED 266555	Referentie Référence	ED 367155
max. 1320 mm	Snijlengte Longueur de coupe	max. 1400 mm
max. 330 mm	Snijdiepte Profondeur de coupe	max. 320 mm
0° → 90°	Hoeksneede Coupe à angle	0° → 90°
90° → 15°	Schuine snede Coupe biseautée	90° → 15°
350°	Temp. snijdraad Temp. fil chaud	350°
40V / 200W / 230V	Transformator Transformateur	42V / 240W / 230V
IP 44	IP-klasse Classification IP	IP 65

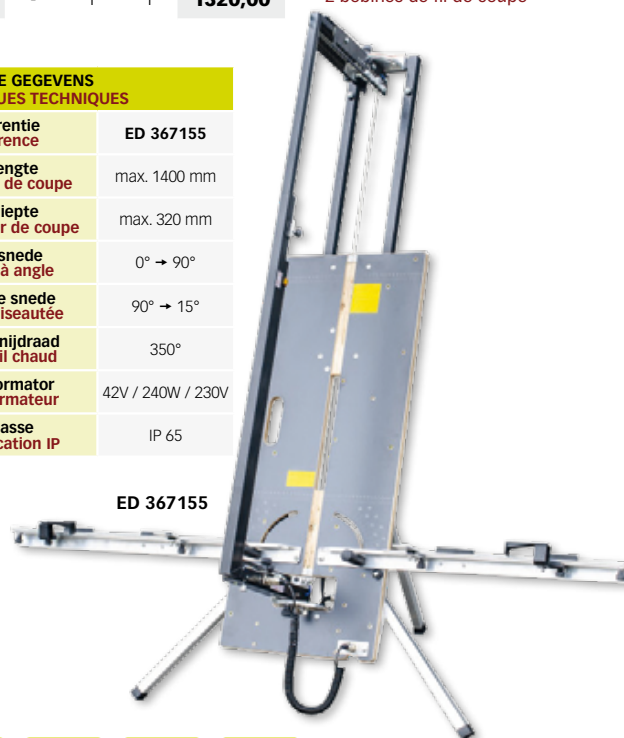

- Inclusief toebehoren :
- Transportkoffer
 - Stelling ondersteuning
 - Plooibare poten
- Accessoires inclus :
- Coffre de transport
 - Support échafaudage
 - Pieds pliables

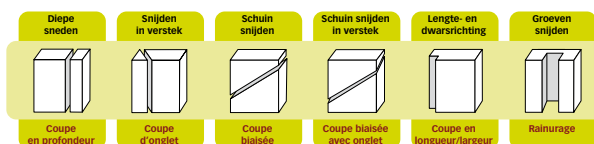

Hulpstuk voor snijden van hoeken voor ED 26655
Accessoire de coupe verticale pour ED 26655

code							min.	€
ED 366655	koffer/coffre	3476060036667	D/P max. 310 mm	9,135 kg	-	1	1	662,00

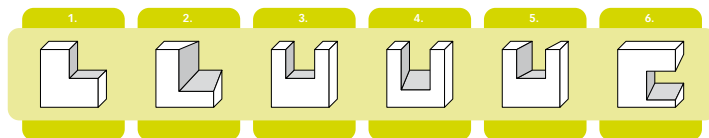

Inclusief toebehoren :

- Li-ion batterij + lader
- Transportkoffer
- 2 posities mogelijk

Accessoires inclus :

- Batterie Li-ion + chargeur
- Valise de transport
- 2 positions possibles

TECHNISCHE GEGEVENS
CARACTÉRISTIQUES TECHNIQUES

Snijdiepte Profondeur de coupe	max. 500 mm
Snijdikte Épaisseur de coupe	max. 310 mm
Hoge positie (hoogte) Position haute (hauteur)	tot/jusqu'à 1000 mm
Lage positie (hoogte) Position basse (hauteur)	tot/jusqu'à 600 mm



± 5 hrs*



± 70 min

 * Gebruik van 20 seconden
 elke 4 minuten
 Utilisation de 20 secondes
 toutes les 4 minutes

Boogzaag met verwarmde snijdraad voor polystyreen
Arche de découpe avec fil chaud pour polystyrène

code							min.	€
ED 266655		3476060026668	H max. 1370 mm D/P max. 330 mm	8,000 kg	-	1	1	338,00

Vervangsnijdraad • Fil chaud de rechange

code								min.	€
voor/pour									
ED 266855	zakje/sachet	3476060026682	1370 mm	ED 266655		0,100 kg	-	1	15,84
ED 366855	zakje/sachet	3476060036681	1500 mm	ED 266555		0,110 kg	-	1	16,48



20 GEREEDSCHAP VOOR AFWERKING OUTILS DE FINITIONS

GEREEDSCHAP VOOR ISOLATIE
OUTILS POUR ISOLATION



EDMAFOAM Polystyreen snijder EDMAFOAM Couteau thermique pour polystyrène



code							min.	€
ED 366755	koffer/coffre	3476060036674	320 W + 1 blad/lame	1,284 kg	-	1	1	223,00
ED 367555	koffer/coffre	3476063675559	320 W + 3 bladen/lames	1,440 kg	-	1	1	325,00
Vervangblad - Lame de rechange								
ED 466755	vrac	3476060046673	200 mm	0,042 kg	-	1	1	45,80
ED 536750	vrac	3476065367506	250 mm	0,042 kg	-	1	1	68,30



ED 466755



"STARTER KIT"

ED 366755



Toebehoren incl:
• Staalborstel
• Montagesleutel
• 1 blad 200 mm

Accessoires incl:
• Brosse métallique
• Clé de montage
• 1 lame 200mm

"KIT EXTRA"

ED 367555



Toebehoren incl:
• 1 blad 200 mm
• 1 blad 250 mm
• 1 groefsnijder 30 mm
• Staalborstel
• Montagesleutel

Accessoires incl:
• 1 lame 200 mm
• 1 lame 250 mm
• 1 rainureuse 30 mm
• 1 brosse métallique
• 1 clé de fixation pour lame



Toebehoren voor polystyreen snijder Accessoires pour couteau thermique polystyrène

code							min.	€
Perforator voor isolatie • Perforateur pour polystyrène								
ED 466455	vrac	3476060046642	D/P min. 25 - max. Ø 70 mm	0,095 kg	-	1	1	52,00
Sleuvenmaker voor isolatie • Rainureuse pour polystyrène								
ED 466555	vrac	3476060046659	Ø 30 mm	0,105 kg	-	1	1	62,50
Snijgeleider voor isolatie • Guide de coupe pour polystyrène								
ED 466655	vrac	3476060046666	L max. 210 mm	0,365 kg	-	1	1	64,50



ED 466455



ED 466655

Ideaal voor een perfecte rechte snede.
Idéal pour une coupe droite parfaite.



ED 466555



Ideaal voor het inbrengen van behuizingen.
Idéal pour l'insertion des boîtiers électriques.



Ideaal voor de doorgang van elektrische leidingen.
Idéal pour le passage des gaines électriques.

Handzaag isolatie PREMIUM 255H Scie isolation PREMIUM 255H

code							min.	€
GM 255H22	vrac	7392746460501	L mm	430 gr	-	10	1	43,00



ZE 8980



LK 650035



LK 644030



LK 665300



Speciaal isolatiemes • Couteau spécial pour matériel isolant

code							min.	€
ZE 8980		5420000010383	mes / lame 140 x 19 x 0,9 mm	166 gr	-	40	1	9,49
ZE 8982		5420000010376	vervangmes / lame de rechange	40 gr	-	50	5	7,15
LK 650035		5420000030657	mes / lame - 340 mm	244 gr	60	10	1	15,54
LK 644030		5420000030640	mes / lame - 280 mm	152 gr	60	10	1	13,40
LK 665300		5420000046184	mes / lame - 300 mm	170 gr	72	12	1	25,00
ED 168055		3476060016805	mes / lame - 420 mm	306 gr	-	5	1	42,30
SR 20975050		5420000057128	mes / lame - 225 mm & 300 mm	251 gr	-	12	1	31,51

ED 168055



SR 20975050



	GLASWOL LAINE DE VERRE	PU-PANELEN PANNEAUX PU	ROTSWOL LAINE DE ROCHE	STYROPOR	SCHUIMPLASTIEK MOUSSE EN PLASTIQUE
ZE 8980	✓	✓	-	-	-
LK 650035	✓	-	✓	-	-
LK 644030	✓	-	✓	✓	✓
LK 665300	✓	-	✓	✓	✓
ED 168055	✓	-	✓	✓	✓
SR 20975050	✓	✓	✓	✓	✓
ED 366202	✓	-	✓	-	-



+EXTRA



Lithium battery
14,4 V

INSULACUT - Elektrische zaag voor minerale wol met extra batterij
INSULACUT - Scie électrique pour isolant minéral avec batterie extra



ED 536621

code							min.	€
ED 366202	koffer/coffre	3476063662023	mes / lame - 300 mm	3200 gr	-	1	1	323,00
Vervangbatterij voor insulacut • Batterie de rechange pour insulacut								
ED 536621	vrac	3476065366219	Lithium 14,4 V	330 gr	-	1	1	70,60
Vervangmes voor insulacut • Lame de rechange pour insulacut								
ED 366355	vrac	3476060036636	300 mm	67 gr	-	1	1	23,84



ED 366355

20 GEREEDSCHAP VOOR AFWERKING OUTILS DE FINITIONS

MENGSTANGEN
MÉLANGEURS



Mengstang type MM 2 • Mélangeur type MM 2

code			schacht tige					min.	€	
		mm	Ø mm	mm						
FC 070206		5420000010222	400	60	8	0,262 kg	72	12	1	7,98
FC 070208		5420000010239	400	80	8	0,313 kg	48	12	1	8,59
FC 070210		5420000010246	600	100	10	0,628 kg	24	6	1	13,09
FC 070212		5420000010253	600	120	10	0,720 kg	18	6	1	17,10

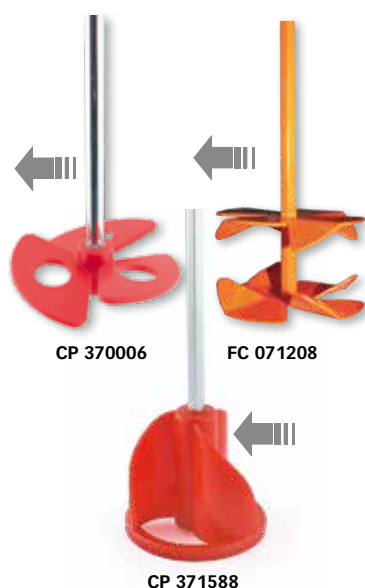
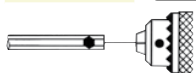

Mengstang type MM 1 • Mélangeur type MM 1

code			schacht tige					min.	€	
		mm	Ø mm	mm						
CP 370006		5420000022676	350	60	6	0,096 kg	-	1	1	3,19
FC 071208		5420000010345	400	80	8	0,313 kg	48	12	1	11,16
Met PVC korf • Avec hélice PVC										
CP 371588	vrac	5420000022683	400	80	8	0,206 kg	-	1	1	7,52



Mengstang type MM 3 • Mélangeur type MM 3

code			schacht tige					min.	€	
		mm	Ø mm	mm						
FC 071612		5420000010260	600	120	12,2	1,026 kg	18	6	1	25,11
FC 071614		5420000010277	600	140	12,2	1,122 kg	18	6	1	25,32

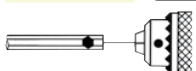

Aansluiting M 14 x 2 • Raccordement M 14 x 2

FC 071512		5420000011229	600	120	14,2	1,186 kg	18	6	1	25,60
FC 071615M		5420000010284	600	140	14,2	1,299 kg	12	6	1	28,52
FC 073428		5420000001107	650	180	18	2,227 kg	-	4	1	31,13
FC 073418		5420000015531	740	180	18	2,406 kg	-	4	1	31,38

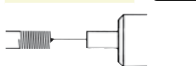

Aansluiting M 18 • Raccordement M 18

FC 075918	vrac	5420000001091	640	180	20,2	1,296 kg	-	4	1	34,35
FC 075865	vrac	5420000024311	640	165	21,3	1,285 kg	-	4	1	33,43

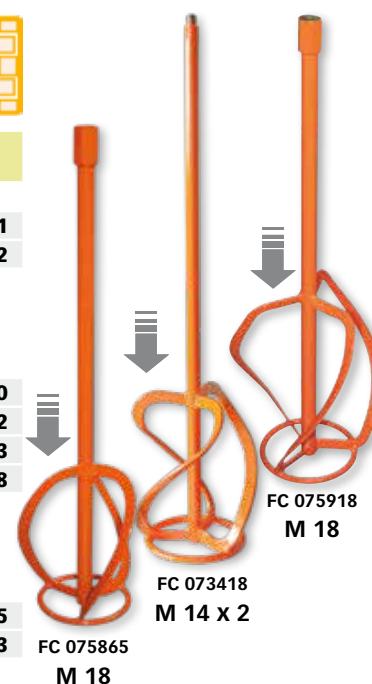
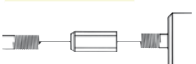

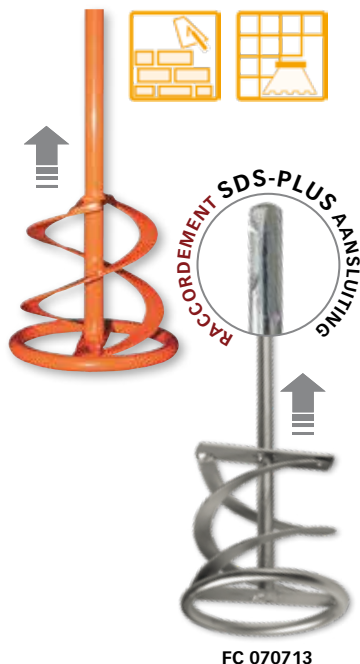

Mengstang type MM 4 • Mélangeur type MM 4

code				schacht tige						min.	€
			mm	Ø mm	mm						
FC 070408		5420000010291	500	80	8	0,381 kg	72	12	1	12,95	
FC 070410		5420000010307	500	100	8	0,426 kg	48	12	1	13,30	
FC 070412		5420000010314	600	120	10	0,841 kg	18	6	1	21,06	

Aansluiting M 14 x 2 • Raccordement M 14 x 2

FC 070512		5420000010321	600	120	14	1,176 kg	18	6	1	23,16
FC 070514		5420000010338	600	140	14	1,318 kg	18	6	1	25,60

SDS-Plus Aansluiting • Raccordement SDS-Plus

FC 070713		5420000060159	600	120	-	1,176 kg	-	1	1	12,40
-----------	--	---------------	-----	-----	---	----------	---	---	---	--------------

LAGE VISCOSITEIT FAIBLE VISCOSITÉ	Wandkleuren • Peintures murales	●●	●●		
	Lak / glazuur • Vernis / Glaçages	●●	●●		
	Lijm • Colle	●	●		
MIDDELHOGE VISCOSITEIT VISCOSITÉ MOYENNE	Kleefmortel • Mortier adhésif			●	●●
	Tegellijm • Colle pour dalles				●●
	Dichtingsmateriaal • Masses d'étanchement				●
	Kleefstof • Adhésifs				●
	Plamuurpasta • Mastic			●	●●
	Voegpasta • Pâte d'étanchéité pour joints		●		●●
	Afwerkmortel • Enduit de finition			●	●●
HOGE VISCOSITEIT HAUTE VISCOSITÉ	Dunnelaagmortel • Revêtement épais				●
	Mortel • Mortier			●	●
	Herstellingsmortel • Mortier de préparation			●	●
	Beton • Béton				●
	Gipspleister • Plâtre				●
	Cementresten • Enduit de ciment			●●	●
	Warmte-isolatieresten • Enduit d'isolation thermique			●●	●
	Bi-component materialen • Matériaux bi-composant			●●	●

Zie ook / Voir aussi p.7 & p.8 EIBENSTOCK

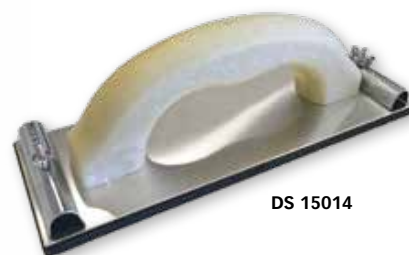

Handschoor der voor schuurgas • Ponceuse à main



code								min.	€
Kunststofbasis • Monture en plastique mm									
PL 284023	vrac	5420000018037	230 x 80	0,240 kg	-	-	40	1	4,83
PL 285024	vrac	5420000000964	235 x 105	0,274 kg	540	-	30	1	5,68
Handgreep in Softgrip + Quick-Clix • Poignée en Softgrip + Quick-Clix									
PL 284500	vrac	5420000044258	230 x 80	0,180 kg	350	-	70	1	6,74
ALU basis • Monture en alliage ALU									
DS 15014	vrac	5420000012608	235 x 85	0,266 kg	600	50	10	1	11,25
Schuurblok in rubber • Bloc de ponçage en caoutchouc									
DS 15010	vrac	5420000003521	120 x 70	0,338 kg	-	72	12	1	4,50

Schoor der met kniegewricht op steel Ponceuse à manche avec articulation

code								min.	€
DS 15045	vrac	5420000012387	240 x 85 mm	0,945 kg	152	4	2		29,08



Schoor gas voor handschoor ders • Grille emeri pour ponceuses à main

code									min.	€
mm										
voorwaarde conditionnement										
KR DC710		5420000018358	280 x 90	per 10 st./par 10 pcs	P 80	0,191 kg	-	50	1	4,30
KR DC122		5420000000025	280 x 105	per 3 st./par 3 pcs	P 100	0,055 kg	-	100	1	2,80
KR DC123		5420000000032	280 x 105	per 10 st./par 10 pcs	P 100	0,172 kg	-	100	1	4,30
KR DC120	vrac	5420000010208	280 x 105	per 50 st./par 50 pcs	P 100	0,783 kg	-	20	1	19,06
KR DC810		5420000018365	280 x 90	per 10 st./par 10 pcs	P 120	0,143 kg	-	100	1	4,30
KR DC910		5420000018372	280 x 90	per 10 st./par 10 pcs	P 220	0,134 kg	-	100	1	4,30



ED 064755

ED 164755

Blokschaaf metaal VARIO RAP • Rabot universel, rape métallique VARIO RAP

code							min.	€
ED 064755		3476060006479	257 mm	0,426 kg	-	5	1	23,24
Vervangblad • Grille de rechange								
ED 164755	vrac	3476060016478	257 mm	0,045 kg	-	1	1	10,10

Blokschaaf metaal • Rabot universel, rape métallique

code								min.	€
DS 14800		5420000003569	250 mm	0,211 kg	432	48	6	1	17,16
Vervangblad • Grille de rechange									
DS 14805		5420000003576	250 mm	0,040 kg	-	-	12	1	6,93

Blokschaaf ALU • Rabot universel, rape ALU

code							min.	€
DS 14831		5420000060517	140 mm	0,100 kg	96	12	1	9,63

Kantensnijder voor gipsplaten
Trusquin de plaquiste pour plaques de plâtre

code							min.	€
DS 15242		5420000012905	max. 120 mm	0,931 kg	-	18	1	22,91

PLAC & ROLL Kantensnijder voor gipsplaten
PLAC & ROLL Trusquin pour la découpe de bandes de plâtre

code							min.	€
ED 062955		3476060006295	max. 150 mm	0,829 kg	-	1	1	54,80





Afkantschaaf voor gipsplaten, met instelbare snijhoek "RAP-PLAC"
Rabot à chanfreiner pour plaques de plâtre, à angle variable "RAP-PLAC"

code							min.	€
ED 069255		3476060006929	22° - 45°	0,572 kg	-	-	5 1	44,50
Vervangmessen - Lames de recharge								Per 5 st • Par 5 pcs
ZE 576060		5420000062962	60 x 0,65 x 19 mm	0,030 kg	3800	200	10 10	1,56



Grote kantensnijder voor gipsplaten • Grand trusquin de plaquiste

code							min.	€
RM 502160		3479135021605	max. 600 mm	0,900 kg	-	1 1	1 1	83,79
inclusief potlood • crayon inclus								



Kantensnijder voor gipsplaten • Trusquin de plaquiste

code							min.	€
RM 502650		3479135026501	max. 100 mm	0,334 kg	-	1 1	1 1	66,15
Vervangmessen • Lames de recharge								Per 5 st • Par 5 pcs
RM 502638		3479135026389	50 x 19 x 0,7 mm	0,020 kg	-	1 1	1 1	6,03

45° kantensnijder • Rabot à chanfreiner 45°

code							min.	€
RM 502618		3479135026181	302 x 160 x 80 mm	0,204 kg	-	1 1	1 1	27,55
Vervangmessen • Lames de recharge								Per 5 st • Par 5 pcs
RM 502638		3479135026389	50 x 19 x 0,7 mm	0,020 kg	-	1 1	1 1	6,03



Dispenser voor voegband (voor gordel)
Dériveur de bande à joint (pour ceinture)



code			A	B	C				min.	€
ED 069855		3476060006981	60	250	50	0,370 kg	5	1	1	15,26

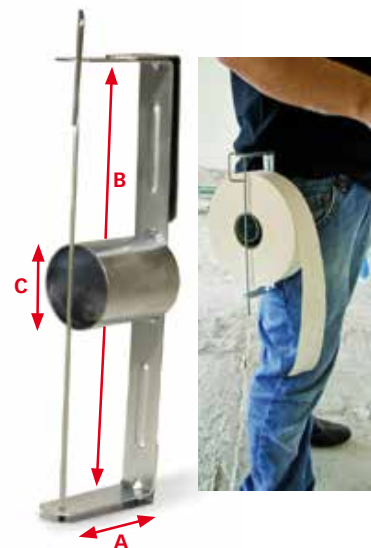

Clinch-on hoekzetter met rubber hamer
Clinch-on fixateur angulaire avec marteau caoutchouc

code							min.	€
DS 15160	vrac	5420000001022	285 mm	1,744 kg	168	3	1	47,45



T - winkelhaak • Équerre - T

code							min.	€
KP 316	vrac	7396329999310	1200 mm	0,650 kg	-	1	1	25,12



Snijregel voor gipsplaten • Règle à découper les plaques de plâtre

code							min.	€
ED 163155	vrac	3476060016317	max. 620 mm	0,611 kg	-	1	1	53,10





PATCH'UP Reparatie patch voor gipsplaten
PATCH'UP Patch de réparation pour plaque de plâtre

code							min.	€
ED 178055		3476061780552	150 x 150 mm	0,056 kg	-	100	1	3,55



Steekzaag, hardpoint vertanding
Scie à guichet, denture trempée hardpoint

G-MAN®

code								min.	€
GM 150H12	vrac	7392746450120	L mm	# inch/pouce	190 gr	-	10	1	15,03
			300	7					



incl. hoesje
housse incl.

Steekzaag ideaal voor gipsplaten, zeer stijf blad
Pognard pour plaque de plâtre, lame très rigide



code								min.	€
			L mm	# inch/pouce					
SOFT GRIP greep • Manche SOFT GRIP									
ED 067055		3476060006707	150	7 - 8	150 gr	-	5	1	19,19
ED 067255		3476060006721	250	7 - 8	250 gr	-	5	1	23,80
Houten greep • Manche bois									
CP 368415	vrac	4022307158167	150	7 - 8	82 gr	-	10	1	5,86

DS 31127

CP 388027



Rattestaart steekrasp • Râpe cylindrique

code							min.	€
DS 31127		5420000012806	300 mm x Ø 5,4 mm	0,084 kg	120	12	1	14,29
CP 388027	vrac	4022307121246	270 mm x Ø 5 mm	0,056 kg	-	1	1	17,52



ED 060055
PROFIL



ED 062055
MASTER PROFIL



Profielverbindingstang • Pince à sertir les profilés

code							min.	€
ED 060055		3476060006004	1 + 1 mm	0,938 kg	-	5	1	61,30
ED 062055		3476060006202	1 + 1 mm	0,710 kg	-	5	1	63,70

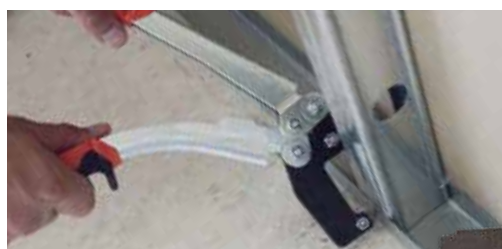

Profielverbindingstang - ERGOTOP Pince à sertir les profilés - ERGOTOP

code							min.	€
ERGOTOP								
ED 061955		3476060006196	1 + 1 mm	0,763 kg	-	5	1	93,10



Profielverbindingstang - ULTRA PROFIL Pince à sertir les profilés - ULTRA PROFIL

code							min.	€
ULTRA PROFIL								
ED 066855		3476060006684	1 + 1 mm	0,825 kg	-	5	1	102,20





3de hand opspantang - 60 kg Étai extensible 3ième main - 60 kg



code				Pads	max 65°	max 90°			min.	€	
			cm	mm							
ED 066155	vrac	3476060006615	160 → 290	200 x 60	20 kg	60 kg	2,219 kg	6	2	1	46,80
ED 067855	vrac	3476060006783	210 → 390	200 x 60	20 kg	60 kg	3,100 kg	6	2	1	63,90



ED 066155 - ED 067855

PAD
200 x 60 mm



IDE 80290

PAD
80 x 60 mm

- Antislip-pads met hoge weerstand, 180° draaibaar en hogere veiligheid door de mogelijkheid om beide uiteinden te fixeren.
- Een sterk ratel-vergrendelingsysteem.
- Eindafstelling met een draadstang aan beide uiteinden.
- Patins de haute résistance, antidérapant, orientables à 180° et sécurité plus importante avec la possibilité de fixation aux deux extrémités.
- Système de blocage à crémaillère de haute résistance.
- Réglage final par une tige filetée aux deux extrémités.



IDE 80125

PAD
80 x 60 mm

3de hand opspantang Étai extensible 3ième main



code				Pads	max 65°	max 90°			min.	€	
			cm	mm							
MINI • 75 → 125 cm											
IDE 80125		5420000060463	75 → 125	80 x 60	20 kg	60 kg	1,750 kg	-	10	1	41,47
STANDA(A)RD • 160 → 290 cm											
IDE 80290		5420000040694	160 → 290	80 x 60	20 kg	60 kg	2,219 kg	-	10	1	45,76





Platendragers voor gipsplaten • Poignées de transport pour plaques

code							min.	€
DUOPLAC per paar • par paire								
ED 064055		3476060006400	140 x 115 mm	1,288 kg	-	10	1	24,67
RM 502100		3479135021001	170 x 145 mm	0,686 kg	-	1	1	37,31
TRANSPLAC								
ED 064555	vrac	3476060006455	565 x 140 mm	1,211 kg	-	2	1	23,99



Platendrager + 2 spieën Porte-plaques + 2 Cales



code							min.	€
KP 258-10	vrac	7290100847220	450 x 180 x 80 mm	0,460 kg	-	4	1	9,85



Voethefboom voor gipsplaten Lève plaque à pied

code							min.	€
FOOTPLAC								
ED 066055		3476060006608	305 x 140 mm	1,025 kg	10	5	1	22,67



Platenklem voor gipsplaten • Cale plaque par blocage

code							min.	€
RM 502050	vrac	3479135020509	H = 80 cm	1,321 kg	-	1	1	35,70

LEVPANO I

CENTRALE REGELBARE ARMEN
BRAS CENTRAUX REGLABLES
0,60 m - 0,90 m - 1,20 m

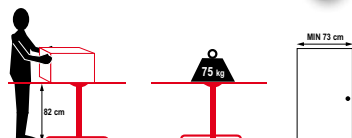
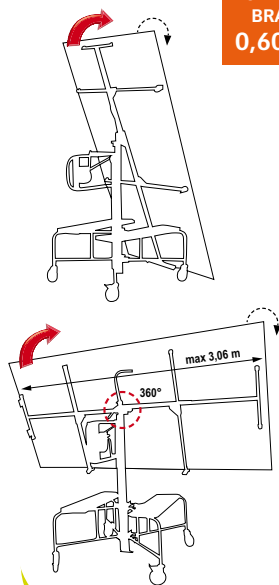

Schuin
Incliné



Horizontaal
Horizontale



ref. RM 513000

€ 1051,00

EAN : 3479135130000



Verticaal
Verticale



LEVPANO II

CENTRALE REGELBARE ARMEN
BRAS CENTRAUX REGLABLES
0,60 m - 0,90 m - 1,20 m

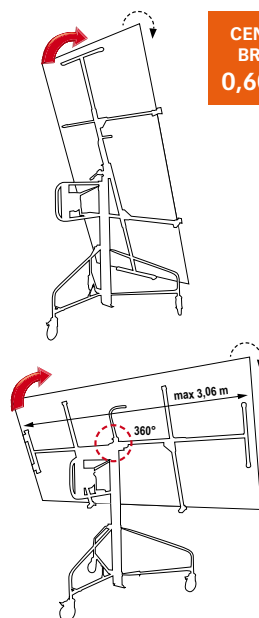

ref. RM 514000

€ 990,00

EAN : 3479135140009



Toebehoren voor LEVPANO I en LEVPANO II
Accessoire pour LEVPANO I et LEVPANO II
PLATFORM • PLATE-FORME - 495 x 505 mm

ref. RM 513200 EAN : 3479135132004

€ 102,00

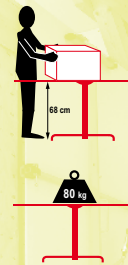
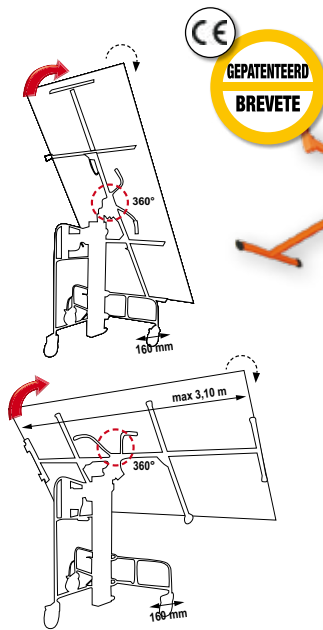

LEVPANO COMBI 400/450

COMBI 400

ref. RM 516500

€ 1596,00

EAN : 3479135165002

COMBI 450

ref. RM 517000

€ 1993,00

EAN : 3479135170006

COMBI 400 & 450

Verlengstuk/Rallonge 0,40 m

ref. RM 516512 inbegrepen/inclus

Voor alle afmetingen

Pour toutes mesures

600/900/1200 mm



LEVPANO EASY

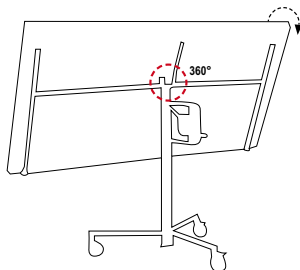

ref. RM 512850

€ 690,00



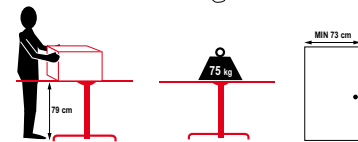



EAN : 3479130000223



	LEVPANO 01	LEVPANO 02	COMBI 400	COMBI 450	LEVPANO EASY
Hoogte plaat horizontaal <i>Hauteur de pose plaque horizontale</i>	4,50 m	4,50 m	3,60 / 4,00 m	4,10 / 4,50 m	3,50 m
Laadhoogte <i>Hauteur de chargement</i>	0,82 m	0,82 m	0,68 m	0,81 m	0,79 m
Laadvermogen <i>Charge utile</i>	75 kg	75 kg	80 kg	80 kg	75 kg
Gewicht machine <i>Poids de l'appareil</i>	52 kg	43 kg	53 kg	55 kg	34 kg
Extra verlengstuk in optie <i>Rallonge extra en option</i>	-	-	0,40 m	0,40 m	0,50 m

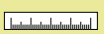





**HOBBY**

HOBBY - Houten schraag • HOBBY - Tréteau en bois

code				 max				min.	€
AS CAB001.99	vrac	8422341100010	B x H 73,5 cm x 73,5 cm	400 kg per/par set	2,100 kg	140	35	35	10,07







**SMAL MODEL
MODÈLE ÉTROIT****PRO 50**

PRO 50 - Houten schraag • PRO 50 - Tréteau en bois

code				 max				min.	€
AS CAB015.99	vrac	8422341199359	B x H 53 cm x 75 cm	400 kg per/par set	2,700 kg	48	6	6	17,79

**ZWAAR MODEL
MODÈLE LOURD****SUPER PRO**

SUPER PRO - Houten schraag • SUPER PRO - Tréteau en bois

code				 max				min.	€
AS CAB014.99	vrac	8422341199342	B x H 73,5 cm x 80 cm	1000 kg per/par set	4,500 kg	40	10	10	32,29

De schragen zijn niet allemaal identiek! • Les tréteaux ne sont pas tous identiques!

Schraag in PVC • Tréteau en PVC

code								min.	€
SK SH020	vrac	8019053040361	B x H 60 cm x 80 cm	200 kg per/par set	5,380 kg	44	1	1	52,60

max

200 kg
per/par set

prijs per paar • prix par paire



Plooibare schraag • Tréteau pliable

code								min.	€
RM 113000	vrac	3479131130004	80 cm	150 kg	3,500 kg	-	2	2	67,94

Regelbare schraag • Tréteau réglable

code								min.	€
RM 113010	vrac	3479131130103	Min. H MAX H 80 cm 130 cm	500 kg	12,000 kg	-	1	1	215,25



ROLL PLAC Mini (2 platen) • ROLL PLAC Mini (2 plaques)



code								min.	€
ED 064655	vrac	3476060646552	85 x 35 cm	80 kg	2,680 kg	-	1	1	70,80



RM 500540

Platenkar 2 wielen • Chariot porte-plaques 2 roues

code								min.	€
RM 500540	vrac	3479135005407	60 x 21 cm	450 kg	12,250 kg	9	1	1	255,15
RM 500550	vrac	3479135005506	80 x 21 cm	900 kg	13,000 kg	12	1	1	320,00



RM 500550



Inklapbare platenkar 4 wielen • Chariot porte-plaques repliable 4 roues

code								min.	€
RM 500560	vrac	3479135005605	83 x 32 cm	900 kg	25,000 kg	3	1	1	531,00